



®

ACTUATECH

ACTUATOR TECHNOLOGY

ALUMINIUM TWO STAGE ACTUATORS

CATALOGUE



www.actuatech.com



®

ACTUATECH

ACTUATOR TECHNOLOGY

**ALUMINIUM
TWO STAGE
ACTUATORS**

CATALOGUE



®

ACTUATECH

ACTUATOR TECHNOLOGY

Il giusto equilibrio tra uomo e ambiente migliora la qualità della vita, garantendo un mondo migliore alle generazioni future.

The right balance between human and environment improves the quality of life, ensuring a better world to future generations.



VISION & MISSION

PASSIONE
PASSION

SENSO DEL DOVERE
SENSE OF DUTY

RISPETTO
RESPECT

Garantiamo un mondo migliore ai nostri figli.
Grazie ai nostri prodotti proteggiamo
l'ambiente che ci circonda e miglioriamo
concretamente la qualità della vita rendendo
più sicuri ed affidabili gli impianti.

*We ensure a better world to our children.
Thanks to our products we take care of
the environment and we improve the
quality of life making safer and
more reliable plants.*



CERTIFICAZIONI AZIENDALI COMPANY CERTIFICATES

DNV

MANAGEMENT SYSTEM CERTIFICATE

Certificate no.: 125286-2012-AE-ITA-ACCREDIA Initial certification date: 05 November 2012 Valid: 06 November 2024 – 05 November 2027

This is to certify that the management system of **ACTUATECH S.p.A.**
Via S. Lorenzo, 70 - 25068 Villa Carcina (BS) - Italy
and the sites as mentioned in the appendix accompanying this certificate

has been found to conform to the Environmental Management System standard:
ISO 14001:2015

This certificate is valid for the following scope:
Design and production of actuators through the phases of die casting, machining, sandblasting, painting, assembly, testing and packaging (IAF 18)
Evaluated according to the requirements of Technical Regulations RT-09

Place and date:
Vimercate (MB), 25 October 2024



For the issuing office:
DNV - Business Assurance
Via Energy Park, 14 - 20871 Vimercate (MB) - Italy



Claudia Baroncini
Management Representative



Lack of fulfillment of conditions as set out in the Certification Agreement may render this Certificate invalid.
ACCREDITED UNIT: DNV Business Assurance Italy S.r.l., Via Energy Park, 14 - 20871 Vimercate (MB) - Italy - TEL: +39 039 68 99 905. www.dnv.it

DNV

MANAGEMENT SYSTEM CERTIFICATE

Certificate no.: CERT-12914-2003-AQ-MIL-SINCERT Initial certification date: 09 September 2003 Valid: 01 August 2024 – 31 July 2027

This is to certify that the management system of **ACTUATECH S.p.A.**
Via S. Lorenzo, 70 - 25068 Villa Carcina (BS) - Italy
and the sites as mentioned in the appendix accompanying this certificate

has been found to conform to the Quality Management System standard:
ISO 9001:2015

This certificate is valid for the following scope:
Design and manufacture of actuators (IAF 17)

Place and date:
Vimercate (MB), 26 July 2024



For the issuing office:
DNV - Business Assurance
Via Energy Park, 14 - 20871 Vimercate (MB) - Italy



Claudia Baroncini
Management Representative



Lack of fulfillment of conditions as set out in the Certification Agreement may render this Certificate invalid.
ACCREDITED UNIT: DNV Business Assurance Italy S.r.l., Via Energy Park, 14 - 20871 Vimercate (MB) - Italy - TEL: +39 039 68 99 905. www.dnv.it



RESPONSABILITÀ SOCIALE SOCIAL RESPONSIBILITY





ATTUATORE DOSATORE IN ALLUMINIO • INDICE

Pag:

ATTUATORI PNEUMATICI

10



- **Attuatore pneumatico dosatore in alluminio**

12

- Tabelle componenti

- Componenti attuatore pneumatico dosatore: GDD 30 ÷ GDD 480

14

- Schema funzionamento attuatore pneumatico doppio effetto "GD"

16

- Schema funzionamento attuatore pneumatico semplice effetto "GS"

17

- Accessori attuatori pneumatici

18

- Certificazioni attuatore dosatore in alluminio 

20



ALUMINIUM TWO STAGE ACTUATOR · INDEX

Pag:

PNEUMATIC ACTUATORS

10



- **Aluminium two stage pneumatic actuator**

12

- *Components' table:*

- *Two stage pneumatic actuator components: GDD 30 ÷ GDD 480*

14

- *Working plane pneumatic actuator "GD" type*

16

- *Working plane pneumatic actuator "GS" type*

17

- *Pneumatic actuators Accessories*

18

- *Aluminium two stage actuator certificates* 

20



ATTUATORI PNEUMATICI PNEUMATIC ACTUATORS

GD DOPPIO EFFETTO *DOUBLE ACTING*

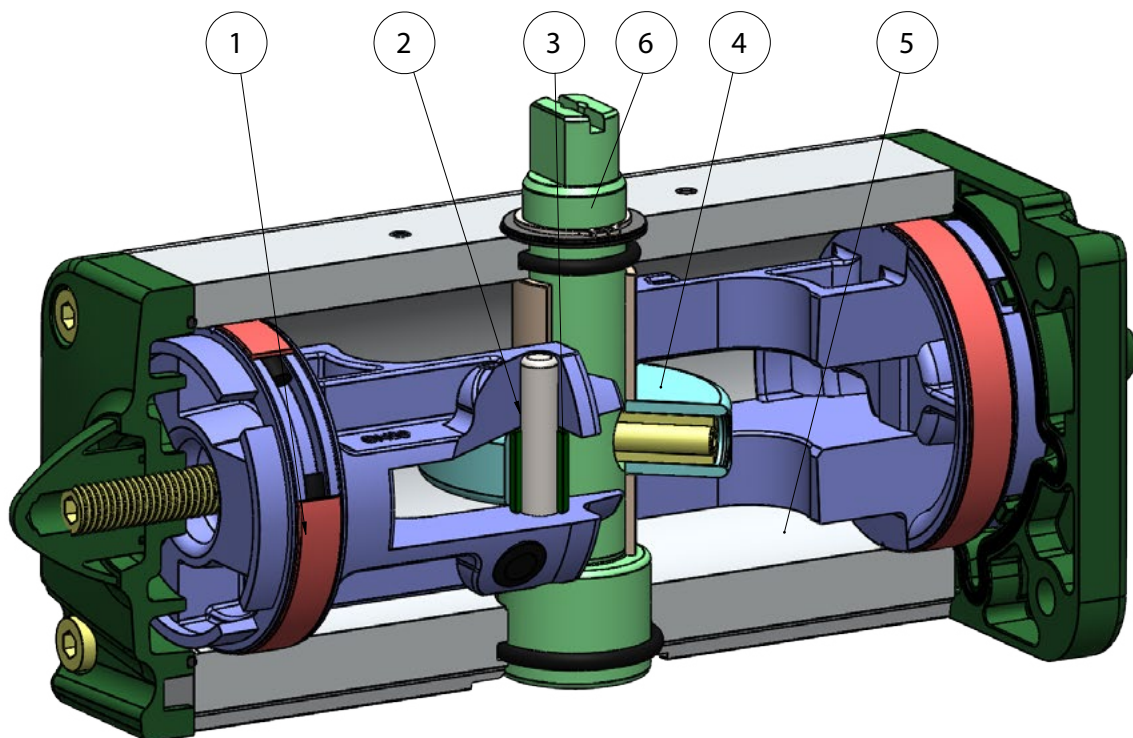

GS SEMPLICE EFFETTO *SPRING RETURN*

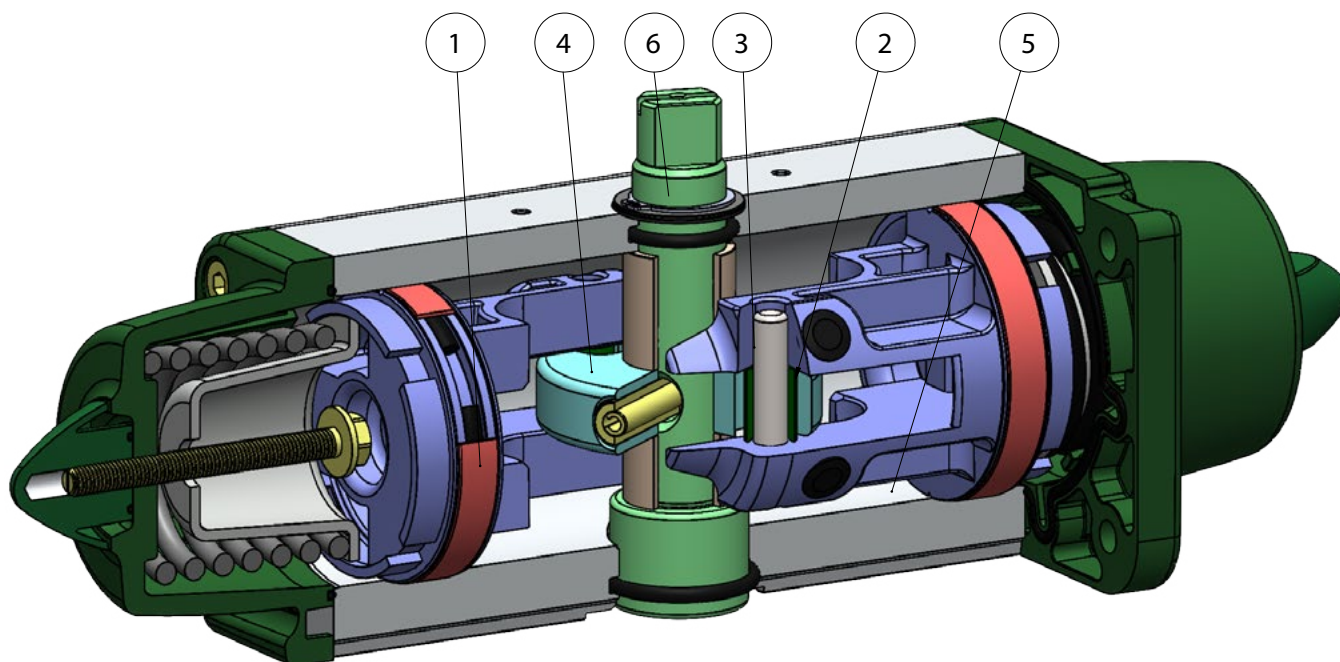



FEATURES & BENEFITS

1	<p>Fasce di tenuta e scorrimento energizzate autolubrificanti.</p> <p><i>Energized and self-lubricated strips.</i></p>	<p>Minor attrito tra pistone e cilindro.</p> <p><i>Less friction between piston and cylinder.</i></p>
		<p>Si evita l'incollaggio della guarnizione al cilindro anche dopo lunghi periodi di fermo.</p> <p><i>It prevents the bonding of the seal to the cylinder even after long periods of inactivity.</i></p>
2	<p>Slot, bussole e spine con acciaio con durezza maggiore a 50 HRC.</p> <p><i>Slots, bushes and pins made by steel with hardness higher than 50 HRC.</i></p>	<p>Maggior resistenza alle forze presenti all' interno dell'attuatore.</p> <p><i>Higher resistance to the forces inside the actuator.</i></p>
3	<p>Attrito volvente tra slot e pistone.</p> <p><i>Rolling friction between piston and slot.</i></p>	<p>Minor attrito.</p> <p><i>Less friction.</i></p>
4	<p>Scotch yoke con attrito volvente (trasformazione del movimento lineare in movimento rotatorio mediante pistone e albero privo di ingranaggi).</p> <p><i>Scotch yoke with rolling friction (transforming rotary motion into linear motion using piston and shaft without teeth/gears).</i></p>	<p>Minor attrito tra pistone e albero con conseguente minor usura dei pezzi.</p> <p><i>Reduced friction between piston and shaft with consequently less wear on the relevant parts.</i></p>
		<p>Momento torcente potenziato in fase di apertura e chiusura.</p> <p><i>Empowered Breakaway Torque (BTO & BTC).</i></p>
		<p>Minor ingombro rispetto agli attuatori pignone e cremagliera con conseguente minor spazio necessario.</p> <p><i>Smaller volume/size than rack and pinion actuators (with the same torque) therefore less space required for installation.</i></p>
		<p>Minor peso rispetto agli attuatori pignone e cremagliera (-30% Kg/Nm) con conseguenti risparmi sulla realizzazione della struttura dell'impianto.</p> <p><i>Less weight than the rack and pinion (-30% kg / Nm), with consequent savings on the construction sizing of the plant/equipment.</i></p>
5	<p>Cilindro rollato.</p> <p><i>Rolled cylinder.</i></p>	<p>Minor usura delle fascette energizzate grazie alla bassa rugosità della superficie.</p> <p><i>Less wear of the energized ties thanks to the low roughness of the surface.</i></p>
		<p>Maggiore resistenza alla corrosione.</p> <p><i>Higher corrosion resistance.</i></p>
6	<p>Albero inox.</p> <p><i>Stainless steel shaft.</i></p>	<p>Maggiore resistenza alla corrosione.</p> <p><i>Higher corrosion resistance.</i></p>
	<p>Interfaccia per elettrovalvole NAMUR integrata dal GD15.</p> <p><i>From sizes bigger than GD15, NAMUR interface for solenoid valve is already integrated.</i></p>	<p>Non richiede alcuna basetta supplementare.</p> <p><i>No need for extra plate.</i></p>
	<p>Processo produttivo interamente eseguito in ACTUATECH.</p> <p><i>100% in- house manufacturing process technology.</i></p>	<p>Massimo controllo in tutte le fasi di lavorazione.</p> <p><i>Maximum control and accuracy in all the stages of the manufacturing process.</i></p>
	<p>Certificato ATEX.</p> <p><i>ATEX Certificate.</i></p>	<p>Ne consente l'installazione in presenza di ambiente potenzialmente esplosivo.</p> <p><i>Installation is allowed in a potential explosive environment.</i></p>
	<p>Certificato fino a SIL 3.</p> <p><i>Up to SIL 3 Certified.</i></p>	<p>Elevato livello di sicurezza funzionale garantito.</p> <p><i>Guarantee of the high level of functional safety.</i></p>



ATTUATORE PNEUMATICO DOSATORE IN ALLUMINIO ALUMINIUM TWO STAGE PNEUMATIC ACTUATOR



<p>DATI TECNICI</p> <ul style="list-style-type: none"> • Angolo di rotazione dosaggio: max 45°. • Angolo di rotazione attuatore: 92° (-1°, +91°). • Momento torcente: vedi tabella degli attuatori relativi. • Nel codice degli attuatori GDD versione standard è indicata la coppia di spunto in Nm alla pressione di 5,6 bar. • Versione ATEX in conformità alla direttiva 2014/34/UE. 	<p>TECHNICAL FEATURES</p> <ul style="list-style-type: none"> • Metering rotation angle: 45° max. • Max. rotation angle: 92° (-1°, +91°). • Torque (see the corresponding actuator tables). • In the code of standard version GDD actuators, it is indicated the breakaway torque in Nm at 5,6 bar air supply. • ATEX version in conformity with directive 2014/34/EU.
<p>CONDIZIONI DI ESERCIZIO</p> <ul style="list-style-type: none"> • Temperatura: da -20°C a +80°C. • Pressione nominale: 5,6 bar; massima di esercizio 8,4 bar. • Fluido di alimentazione: aria compressa filtrata secca non necessariamente lubrificata. In caso di lubrificazione usare olio non detergente, compatibile con NBR. 	<p>WORKING CONDITION</p> <ul style="list-style-type: none"> • Temperature: from -20°C to +80°C. • Air supply: 5,6 bar; maximum 8,4 bar. • Actuating media: filtered dry compressed air, not necessarily lubricated. In case of lubricated air, either non detergent oil, NBR compatible oil, must be used.

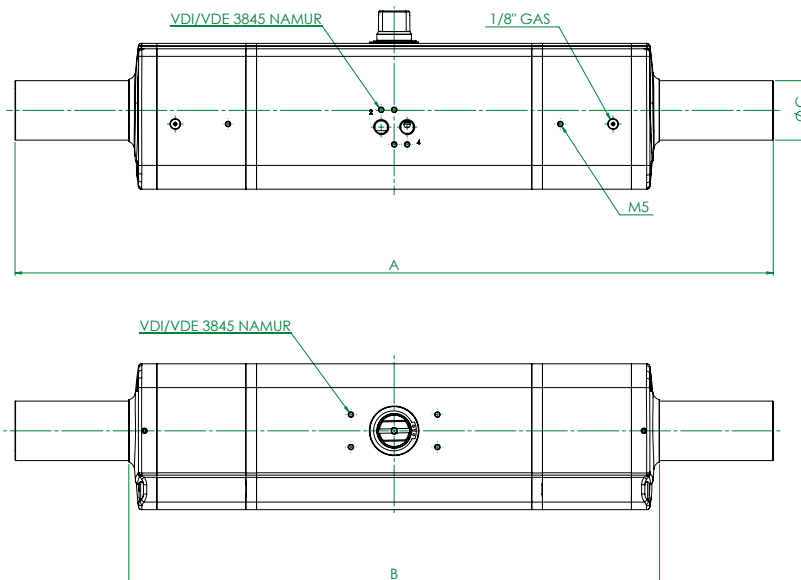

SCHEDA TECNICA DATA SHEET							
Codice Code	GDD00300311S	GDD00300411S	GDD00600414S	GDD00600514S	GDD01060517S	GDD02400722S	GDD04801027S
Misura Size	GDD 30 F03-F05	GDD 30 F04	GDD 60 F04	GDD 60 F05-F07	GDD 106 F05-F07	GDD 240 F07-F10	GDD 480 F10-F12
A [mm]	355	355	423	423	502	589	702
B [mm]	245	245	278	278	345	416	491
C [mm]	29	29	29	29	29	40	55
Aria corsa totale Full stroke air (dm ³ /cycle)	0,17	0,17	0,31	0,31	0,57	1,3	2,46
Aria corsa parziale Partial stroke air (dm ³ /cycle)	0,18	0,18	0,33	0,33	0,59	1,36	2,55
peso weight Kg.	1,8	1,8	2,8	2,8	4,7	8	14,3



SCHEMA DI FUNZIONAMENTO WORKING PLANE

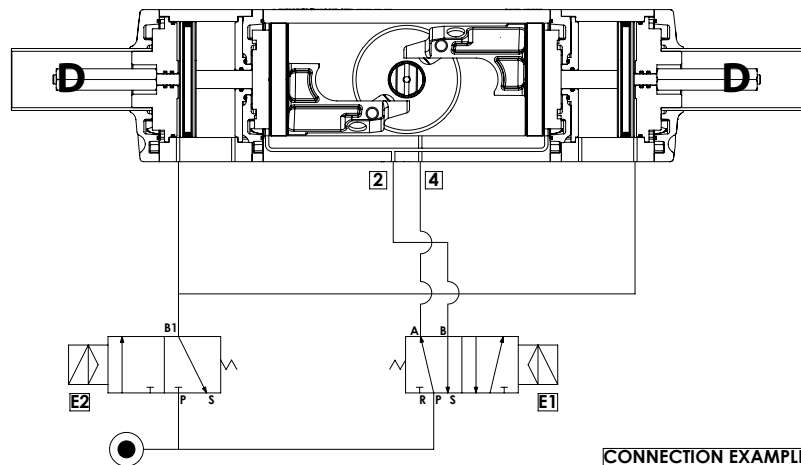

Condizioni generali di utilizzo e principio funzionamento

UTILIZZO: Riempitura-Dosaggio di materie liquide o semisolidi tramite il dispositivo di dosatura.

Attuatore a doppia azione per dosaggi grossolani o fini.

ESECUZIONE: Secondo EN ISO 5211, conforme a EN 15714-3.

METODO DI LAVORO: Il modello base è l'attuatore ACTUATECH doppio effetto. Ad esso sono stati aggiunti due cilindri ai cui interno i pistoni, solidali ad un asta, la spingono longitudinalmente facendo da fermo ai pistoni dell'attuatore impedendo così la completa rotazione del meccanismo ed incidendo sulla portata totale della valvola. Il dispositivo funziona tramite le due elettrovalvole E1 = 5/2; E2 = 3/2. Dove E1 comanda l'attuatore mentre E2 i due cilindri esterni. Con riferimento alle elettrovalvole nel disegno vediamo alcuni esempi:

-con VALVOLA TUTTA CHIUSA (0°) avremo:

E1: A in pressione e B allo scarico; E2: B1 allo scarico.

-Con VALVOLA TUTTA APERTA (90°) regolazione grossolana avremo:

E1: A allo scarico e B in pressione; E2: B1 allo scarico.

Al raggiungimento del valore previsto es. 90% del riempimento totale del contenitore, il segnale di grossolano (valvola tutta aperta) viene escluso e l'aria, passando per E2 e successivamente cambiando la posizione di E1, raggiunge i pistoni esterni i quali, muovendosi, eseguono l'angolo di chiusura desiderato, es. 30° (regolazione fine), provocando così la riduzione voluta della portata.

Con VALVOLA APERTA es. 30° regolazione fine avremo:

E1: A in pressione e B allo scarico; E2: B1 in pressione.

Questa posizione intermedia e la relativa portata della valvola verrà riprodotta con assoluta fedeltà e precisione ad ogni ripetizione del procedimento.

N.B. la regolazione voluta può variare da 0° a 45° tramite il controdado D.

Quando il valore teorico combaccerà con quello effettivo, verrà escluso il segnale di regolazione fine che si trova su E2 (B1 allo scarico); l'attuatore comincerà a muoversi ottenendo così la chiusura totale della valvola. Con ciò è da ritenersi concluso il procedimento di Riempitura-Dosaggio.

IN CONCLUSIONE: Il dispositivo ACTUATECH può essere installato ovunque sia richiesto di fornire esattamente le stesse quantità per lunghi cicli di lavoro.

General use and working condition

USE: Filling and metering of fluids or solids-mix materials by means of a special metering device.

Double acting actuator for fine or rough metering.

EXECUTION: According to EN ISO 5211, in compliance with EN 15714-3.

WORKING SYSTEM: The basic model consists of an ACTUATECH double acting actuator, equipped with two additional cylinders whose inner-pistons, by means of a stroke adjustment device, stop the rotating angle of the actuator to a pre-set position, preventing it from a complete rotation and influencing the total valve flow pressure.

This device is driven by two solenoid valves.

E1 = 5/2; E2 = 3/2. E1 drives the actuator, while E2 drives the two external cylinders.

Some examples referring to the valves in the drawing above:

-with a completely CLOSED VALVE (0°) You will have:

E1: air supply in A, exhausts in B

E2: exhausts in B1.

-with a completely OPEN VALVE (90°) rough metering You will have:

E1: exhausts in A, air supply in B

E2: exhausts in B1.

When You reach the desired level, e.g. 90% of the total filling, the rough signal (completely open valve) will turn off and the air, flowing through E2 and then changing the position of E1, will get to the external pistons which will move to the desired rotating angle, e.g. 30° (fine metering), consequently reducing the total valve flow.

With an OPEN VALVE, e.g. 30° fine metering, You will have:

E1: air supply in A, exhaust in B;

E2: air supply in B1

This intermediate position and the corresponding valve flow pressure will be reproduced, whenever you repeat the process.

NOTE: Thanks to control "D", the desired metering can range from 0° to 45°. When the desired level is the same as the actual one, the fine-metering signal on E2 (exhaust in B1) will turn off; the actuator will start moving and make the valve close, completely. Now the filling and metering process is over.

CONCLUSION: ACTUATECH device can be assembled wherever you need to furnish exactly the same quantities in long working cycles.

A. POSIZIONE TOTALMENTE CHIUSO FULLY CLOSED POSITION

In questa posizione l'attuatore è alimentato nella porta 4, con le porte 2 e 6 in scarico.

In this position the air is supplied to port 4 with exhaust air at port 2 and 6.

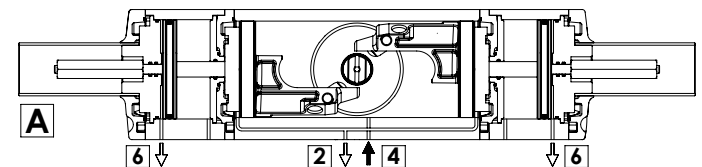

B. POSIZIONE TOTALMENTE APERTO (approssimativamente 90°) FULLY OPEN POSITION (90° rough metering)

In questa posizione l'attuatore è alimentato nella porta 2, con le porte 4 e 6 in scarico.

In this position the air is supplied to port 2 with exhaust air at port 4 and 6.

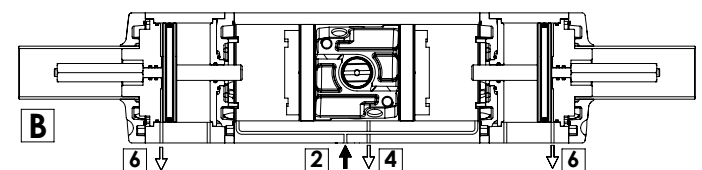

C. POSIZIONE INTERMEDIA (misura precisa) INTERMEDIATE POSITION (fine metering)

In questa posizione l'attuatore è alimentato simultaneamente nella porta 6 e 4, con la porta 2 in scarico. In questo caso i pistoni esterni si muoveranno raggiungendo l'angolo desiderato; di conseguenza verrà ridotto il flusso totale della valvola.

In this position the air is supplied to port 6 than to port 4, with exhaust air at port 2. In this case the external pistons will move to the desired rotating angle, consequently reducing the total valve flow.

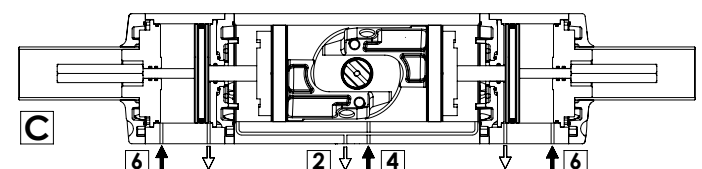



COMPONENTI ATTUATORE PNEUMATICO DOSATORE: GDD 30 ÷ GDD 480
TWO STAGE PNEUMATIC ACTUATOR COMPONENTS: GDD 30 ÷ GDD 480

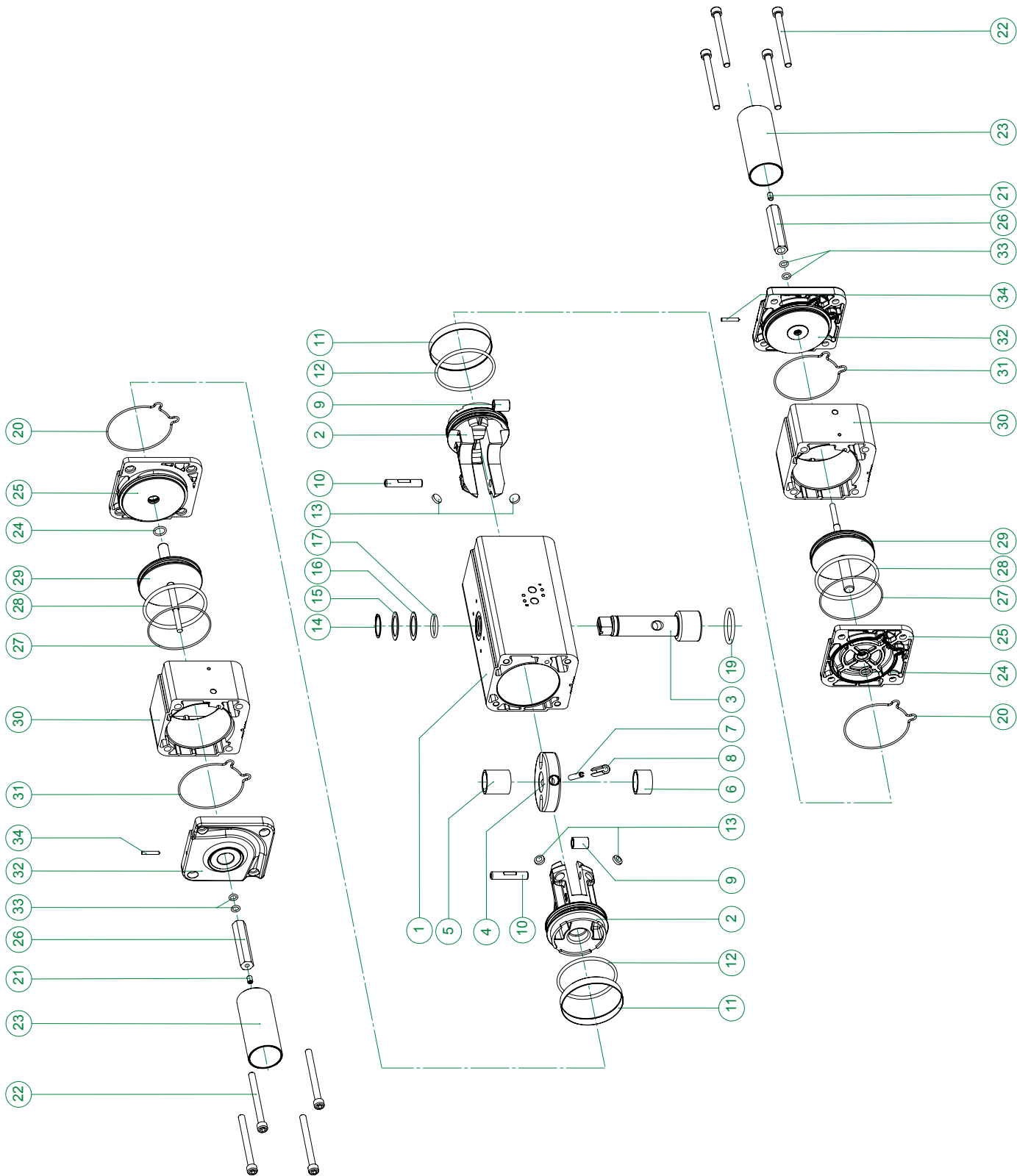



MATERIALI MATERIALS				
Pos	Denominazione	Denomination	Q.ty	Materiale Material
18	Anello di centraggio	Centering ring (OPTIONAL)	1	Lega di alluminio Aluminium alloy
19	O-ring inferiore albero	O-ring	1	FKM
20	O-ring tenuta tappo	O-ring	2	Gomma nitrilica Nitrilic rubber
21	Grano bloccaggio regolazione	Grub screw	2	Acciaio inox Stainless steel
22	Viti screws		8	Acciaio inox Stainless steel
23	Protezione	protection	2	Lega di alluminio Aluminium alloy
24	O-ring int.tappo intermedio	Support bush	2	FKM
25	Tappo intermedio	Intermediate cap	2	Lega di alluminio Aluminium alloy
26	Controdado di regolazione	Adjusting nut	2	Lega di alluminio Aluminium alloy
27	O-ring est.tappo intermedio	O-ring	2	Gomma nitrilica Nitrilic rubber
28	O-ring pistone ausiliario	O-ring	2	Gomma nitrilica Nitrilic rubber
29	Pistone ausiliario	Auxiliary piston	2	Lega di alluminio Aluminium alloy
30	Cilindro ausiliario	Auxiliary cylinder	2	Lega di alluminio Aluminium alloy
31	O-ring tappo finale	O-ring	2	Gomma nitrilica Nitrilic rubber
32	Tappo finale	Terminal cap	2	Lega di alluminio Aluminium alloy
33	O-ring interne tappo finale	O-ring	4	FKM
34	Grano bloccaggio protezione	Grub screw	2	Acciaio inox Stainless steel

MATERIALI MATERIALS				
Pos	Denominazione	Denomination	Q.ty	Materiale Material
1	Cilindro	Cylinder	1	Lega di alluminio Aluminium alloy
2	Pistone	Piston	2	Lega di alluminio Aluminium alloy
3	Albero	Shaft	1	Acciaio inox Stainless steel
4	Forcella	Scotch yoke	1	Lega di acciaio Steel alloy
5	Bussola scorrimento supporto	Bush	1	Resina acetica Acetalic resin
6	Bussola di scorrimento	Bush	1	Resina acetica Acetalic resin
7	Spina elastica interna	Int.elastic pin	1	Lega di acciaio Steel alloy
8	Spina elastica esterna	Ext.elastic pin	1	Lega di acciaio Steel alloy
9	Bussola acciaio	Bush	2	Lega di acciaio Steel alloy
10	Perno	Sleeve	2	Lega di acciaio Steel alloy
11	Anello di tenuta	Dynamic seal	2	Poliuretano Polyurethan
12	O-ring del pistone	O-ring	2	Gomma nitrilica NBR
13	Dischetto di supporto	Support disks	4	P.T.F.E. carbo-graphite filled
14	Seeger		1	Acciaio inox Stainless steel
15	Rondella di spessoramento	Washer	1	Acciaio inox Stainless steel
16	Anello supporto esterno	Ext.support ring	1	Resina acetica Acetalic resin
17	O-ring albero superiore	O-ring	1	FKM



SCHEMA FUNZIONAMENTO ATTUATORE PNEUMATICO "GD" WORKING PLANE PNEUMATIC ACTUATOR "GD" TYPE

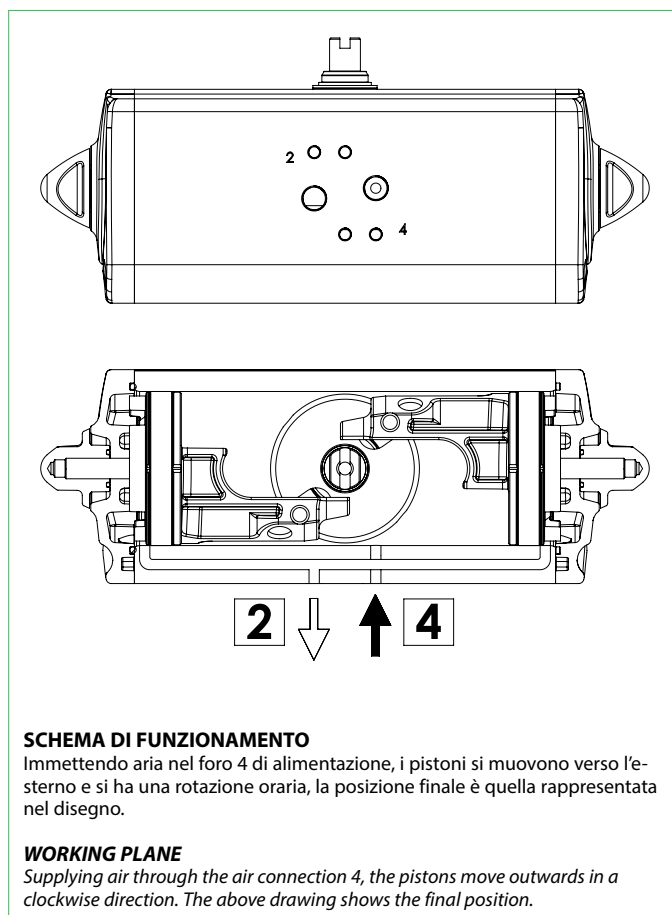
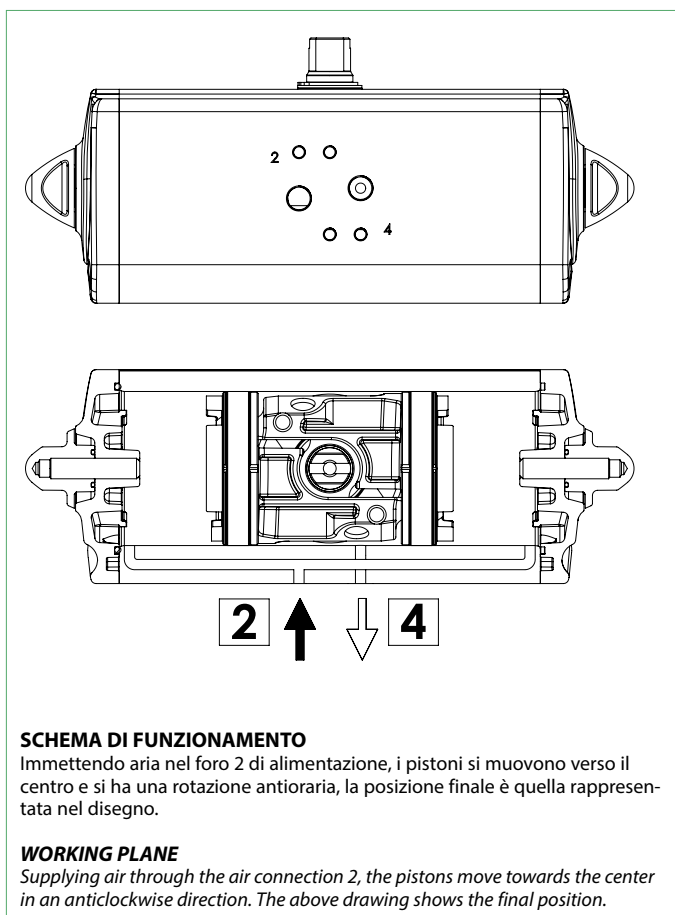

ATTUATORE REGOLABILE-ISTRUZIONI PER L' UTILIZZO ACTUATOR WITH STROKE ADJUSTMENT-INSTRUCTIONS

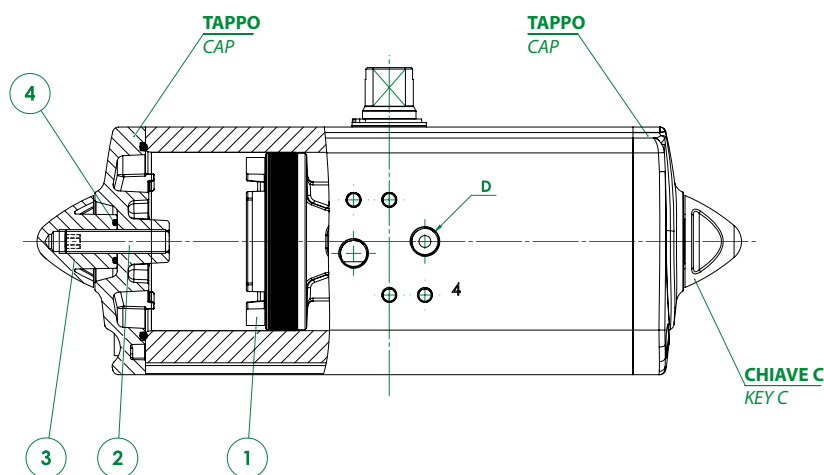

- A)** Immettere aria nel foro "D" in modo che i pistoni (part. n°1) si vengano a trovare in posizione di finecorsa verso i tappi.
B) Togliere il controdado (part. n°3) agendo sulla chiave C.
C) Togliere l'aria di alimentazione.
D) Con una chiave a brugola agire sulle viti (part. n°2) ed effettuare la limitazione di corsa desiderata.
N.B. La corsa può essere limitata per un massimo di 10° da 80° a 90°. Altre regolazioni disponibili a richiesta.
E) Mettere aria nel foro "D", verificare che entrambe le viti (part. n°2) siano a battuta contro i pistoni.
F) Mettere il controdado (part. n°3) munito di O-ring (part. n°4) per la tenuta tra dado e tappo.

N.B. queste spiegazioni sono indicative, per le istruzioni operative, vedere il manuale.

- A)** Supply air through the air connection D so that the pistons (Part. 1) move to the end-stroke position, towards the caps.
B) Remove the counter nut (part. 3) acting on the C key.
C) Shut off the air supply.
D) Adjust the end stroke as desired, acting on the screws (part 2) with an hexagonal key.
Note: maximum adjusting stroke 10°, ranging from 80° to 90°. Other regulations on request.
E) Supply air through the air connection D and check that both screws stop the pistons.
F) Screw the counter-nut (part 3) and its o-ring (part 4) to keep nut and cap tight.

N.B. these explanations are indicative, for operating instructions, see the manual.



SCHEMA FUNZIONAMENTO ATTUATORE PNEUMATICO "GS" WORKING PLANE PNEUMATIC ACTUATOR "GS" TYPE

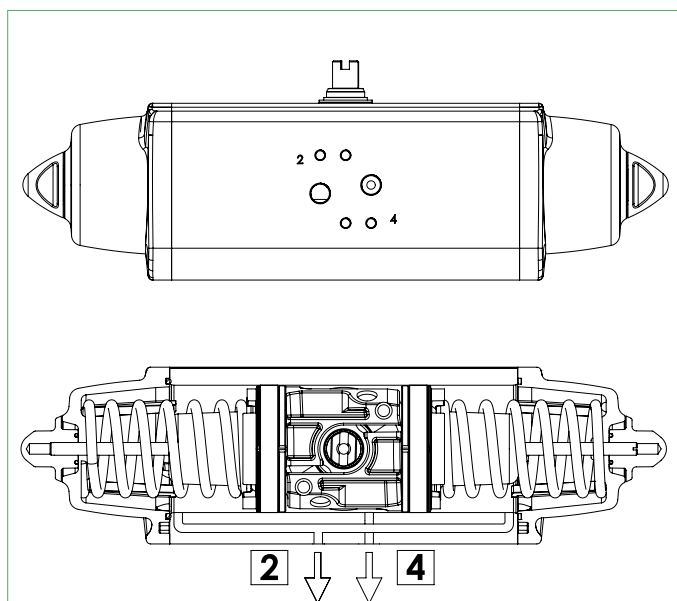

SCHEMA DI FUNZIONAMENTO

Senza pressione di alimentazione, nella versione semplice effetto, l'attuatore torna automaticamente in posizione di riposo compiendo una rotazione oraria e la posizione finale è quella rappresentata nel disegno. Sul foro 2 è consigliato montare un filtrino onde evitare che polvere o particelle solide possano entrare nella camera del cilindro senza tuttavia impedire il passaggio dell'aria.

WORKING PLANE

Without air supply, the spring return actuator returns to its resting position, rotating in a clockwise direction. The drawing shows its final position. We assembling a small filter on the air connection 2 to prevent dust and particles into the cylinder chamber without, however, preventing the passage of air.

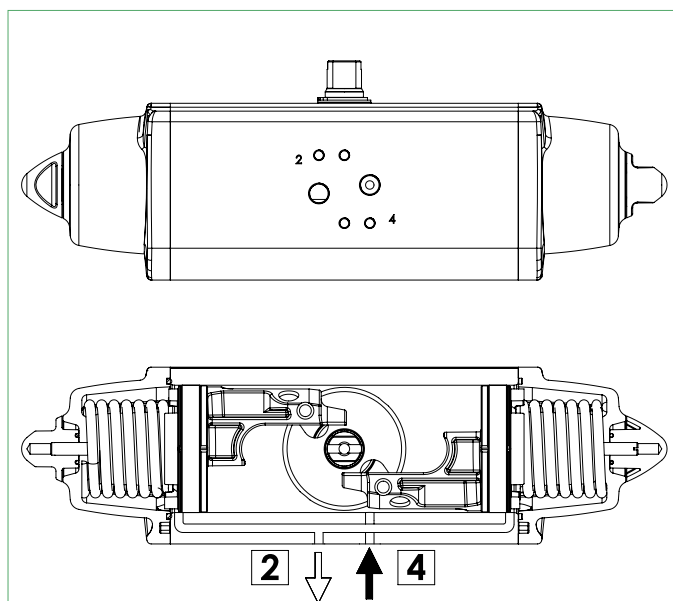

SCHEMA DI FUNZIONAMENTO

Immettendo aria nel foro 4 di alimentazione, i pistoni si muovono verso l'esterno comprimendo le molle, si ha una rotazione antioraria e la posizione finale è quella rappresentata nel disegno.

WORKING PLANE

Supplying air through the air connection 4, the pistons move outwards pressing the spring. An anticlockwise rotation takes place and the final position is shown above.

ATTUATORE REGOLABILE-ISTRUZIONI PER L' UTILIZZO ACTUATOR WITH STROKE ADJUSTMENT-INSTRUCTIONS

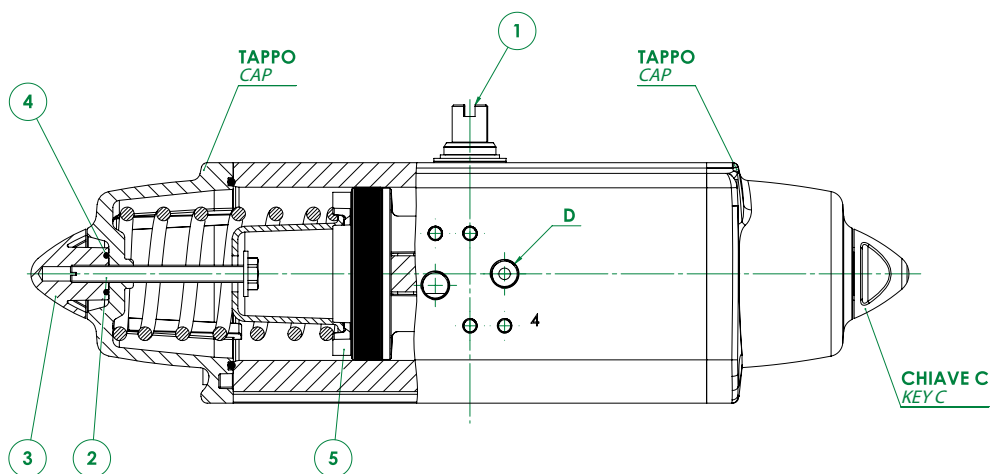

- A) Verificare che le molle siano in posizione di riposo osservando la chiave dell'albero (part. n°1) come da disegno e controllando che nel foro "D" non ci sia pressione.
- B) Togliere i controdadi (part. n°3) agendo sulla chiave C.
- C) Con un cacciavite avvitare le viti (part. n°2) in senso orario ed effettuare la limitazione di corsa desiderata.
- N.B. La corsa può essere limitata per un massimo di 10° da 80° a 90°
- D) Immettere aria nel foro "D" e verificare che entrambe le viti (part. n°2) siano a battuta contro i pistoni (part. n°5).
- E) Bloccare i controdadi (part. n°3) muniti di O-ring (part. n°4) per la tenuta tra controdado, tappo e vite.

N.B. queste spiegazioni sono indicative, per le istruzioni operative, vedere il manuale.

- A) The springs must be at rest position, the shaft (part. 1) must be as shown in the drawing. Air connection D must not be supplied with air.
- B) Remove the counter-nuts (part. 3), acting on key C.
- C) By means of a screwdriver turn screws (part. 2) in a clockwise direction until you obtain the requested end-stroke regulation.
- Note: maximum adjusting stroke 10°, ranging from 80° to 90°.
- D) Supply connection D with air pressure and check that both adjusting screws (part. 2) stop the pistons (part. 5).
- E) Screw the counter-nuts (part. 3) and their O-ring (part. 4) to keep nut and cap tight.

N.B. these explanations are indicative, for operating instructions, see the manual.



ACCESSORI ATTUATORI PNEUMATICI PNEUMATIC ACTUATORS ACCESSORIES

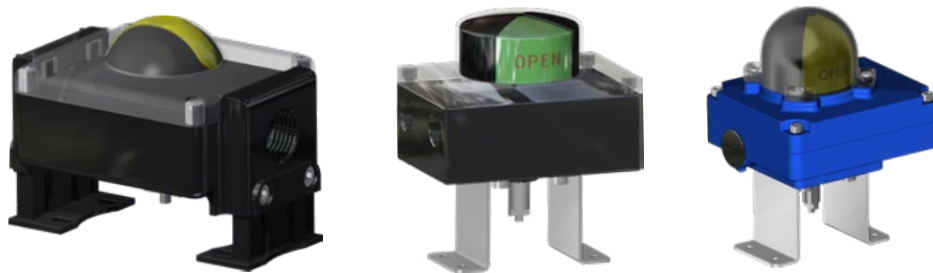

BOX DI SEGNALAZIONE CON FINECORSA
LIMIT SWITCH BOX



OPERATORE MANUALE DI SBLOCCO
MANUAL OVERRIDE WITH HAND WHEEL



ELETTROVALVOLE
SOLENOID VALVES



ELETTROVALVOLE NAMUR
NAMUR SOLENOID VALVES



POSIZIONATORE PNEUMATICO
PNEUMATIC POSITIONER



POSIZIONATORE ELETTROPNEUMATICO
(SICUREZZA INTRINSECA)
ELECTROPNEUMATIC POSITIONER
(INTRINSICALLY SAFE)

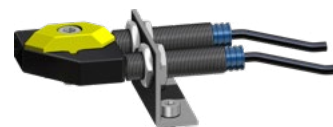

FINECORSA DI PROSSIMITA'
PROXIMITY LIMIT SWITCHES

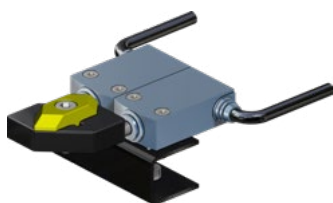

FINECORSA ELETTROMECCANICI
ELECTROMECHANICAL LIMIT SWITCHES



FINECORSA PNEUMATICI
PNEUMATIC LIMIT SWITCHES

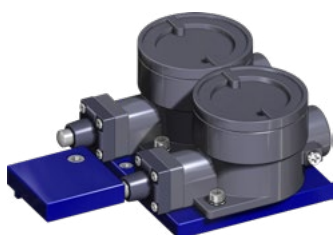

FINECORSA ANTIDEFLAGRANTI II2GD ExdIIC
EXPLOSION PROOF LIMIT SWITCHES II2GD ExdIIC

Per maggiori informazioni consultare **Catalogo Accessori ACTUATECH.**
For more information check the **ACTUATECH Accessories Catalogue.**



CERTIFICAZIONI ATTUATORE DOSATORE IN ALLUMINIO ALUMINIUM TWO STAGE ACTUATOR CERTIFICATES



◀ ATEX (Pneumatic actuator ATEX compliance)

ACTUATECH progetta e produce i propri prodotti in conformità alla direttiva ATEX, la quale regola l'impiego di apparecchiature in ambienti con atmosfere esplosive.

ACTUATECH designs and manufactures our products in accordance with the ATEX directive, which regulates the use of equipment in explosive atmospheres.





ACTUATECH
ACTUATOR TECHNOLOGY

GDD010605175

Villa Carcina
Brescia
ITALY

Type: GDD106-F05/07
Pnom = 5,6 bar
Tmin = -20°C

Pmax = 8,4 bar
Tmax = +80°C



ACTUATECH S.p.A.



Ph. +39 030 8908142 - Fax +39 030 8908143 - actuatech@actuatech.com - www.actuatech.com

VILLA CARCINA HEADQUARTERS

Via San Lorenzo, 70 - 25069 Villa Carcina (BS) ITALY

Coordinates:

Lat: 45° 39' 09.6" North; Lon: 10° 11' 49.5" East

SAREZZO SITE

Via Fratelli Capponi, 126 - 25068 Sarezzo (BS) ITALY

Coordinates:

Lat: 45° 39' 48.5" North; Lon: 10° 11' 39.4" East